

BE SURE TO REGISTER ELT

EBC-406AFH

EMERGENCY LOCATOR TRANSMITTER OPERATING AND MAINTENANCE MANUAL

FOR HELICOPTER USE ONLY

**EMERGENCY BEACON CORPORATION
15 RIVER STREET
NEW ROCHELLE, NEW YORK 10801
Phone: (914) 235-9400 / 576-2700
Fax: (914) 576-7075
E-mail: emergencybeacon@verizon.net
Web: www.emergencybeaconcorp.com**

November 17, 2011
Rev. 3

EMERGENCY BEACON CORPORATION
15 RIVER STREET
NEW ROCHELLE, N.Y. 10801
TEL: 914/235-9400; FAX: 914/576-7075
(e-mail: emergencybeacon@verizon.net)

A D D E N D U M

When installing the EBC-406AF-series ELT in a location where humidity can be an issue, seal the backside of the 15-pin harness D-connector (especially the soldered pins) to keep out any moisture as moisture may cause the ELT to activate. Once the sealant has been applied, the plastic backshell can be installed on the D-connector.

Also, place a bead of sealant around the outside metal shell of the beacons' 15-pin connector to keep moisture from wicking its way onto the mating surfaces.

When installing the EBC-406AF-series ELT in a location where humidity can be an issue, seal the backside of the D-connector on the mounting bracket.

TABLE OF CONTENTS

SECTION 1	4
GENERAL DESCRIPTION	4
SECTION 2	5
REGISTERING YOUR ELT (USA)	5
SECTION 3	6
DESCRIPTION OF ELT TOGGLE SWITCH POSITIONS	6
SECTION 4	7
DESCRIPTION OF REMOTE CONTROL MONITOR TOGGLE SWITCH POSITIONS	7
SECTION 5	7
ELT INSTALLATION	7
SECTION 6	8
EXTERNAL ANTENNA INSTALLATION (ANT-406W)	8
SECTION 7	9
REMOTE CONTROL MONITOR INSTALLATION	9
SECTION 8	10
FINAL INSTALLATION AND TEST	10
SECTION 9	11
DESCRIPTION OF SELF-TEST MODE AND ERROR CODES	11
MEANING OF ERROR CODES	11
SECTION 10	12
OPERATING INSTRUCTIONS	12
SECTION 11	13
PERIODIC MAINTENANCE	13
SECTION 12	13
EQUIPMENT LIMITATIONS	13
SECTION 13	14
BATTERY REPLACEMENT	14
GS-46 ENVIRONMENTAL QUALIFICATION FORM	15
EBC-406AFH ENVIRONMENTAL QUALIFICATION FORM	16
SECTION 14	17
REPAIRS	17
SECTION 15	17
SPECIFICATIONS	17
SECTION 16	18
EBC-406 TWO YEAR WARRANTY	18
NOAA Registration Form	

SECTION 1 GENERAL DESCRIPTION

The EBC-406AFH is designed for helicopter installation. It meets the requirements of TSO-C126 in the Automatic Fixed (AF) category. The EBC-406AFH is installed in the aft section of the fuselage. The ELT is constructed of aluminum, the toggle switch is recessed, and the electronics and the activation system are completely encapsulated to seal out moisture and other contaminants that could compromise performance. Our encapsulation method also provides added protection against vibration and shock. The EBC-406AFH will radiate a distress signal on 406.028 MHz and 121.500 MHz.

There are two recessed areas on the ELT, one on the top, housing a 3-position toggle switch, LED, and the antenna connector. The recessed toggle switch provides added protection against inadvertent activation and damage. The other recessed area is on the bottom. It houses a 15-pin female, D-Sub connector, used to connect the ELT to the Remote Control Monitor. The mating connector must be wired with a G-switch loop back to enable the G-switch when mated with the ELT connector.

The Remote Control Monitor has a 3-position toggle switch, an LED, and a buzzer. It is used for remote operation of the ELT, to indicate when the ELT is transmitting, and to indicate pass or fail after a self-test is completed.

To prevent inadvertent activation, the G-switch is disabled when the mating connector is removed.

No external power connections are required. All indicators and controls are powered from the ELT's battery pack.

The following is a list of the basic parts used with the EBC-406AFH.

<u>Description</u>	<u>Part Number</u>
Transmitter	EBC-406AFH
Mounting Tray for Aft Mount	BB-14
Coaxial Cable 72"	AC-406
External Whip Antenna	ANT-406W
Remote Control Monitor Connector Kit	RCM-1 KIT
Remote Control Monitor	RCM-1
Portable Tape Antenna	ANT-406T
Battery Pack	GS-46

The following accessories can be used with the EBC-406AFH

Description

External High-Speed Rod Antenna – ANT-406R
External High-Speed Blade Antenna – ANT-406B

SECTION 2 REGISTERING YOUR ELT (USA)

The United States requires that every 406 ELT be registered by the aircraft owner after installation, re-registered every two years, and re-registered if there are any changes to information provided to NOAA in a previous registration, such as telephone numbers, aircraft registration number, change of owner, ...etc.

Every 406 ELT has a unique identification code used by the Rescue Coordination Center to determine if an emergency has actually occurred. This unique identifier is stored in a database maintained by NOAA, It can then be accessed to contact the owner in the event of an ELT activation. Registration is free, and can even be done via the Internet on the NOAA website at: www.sarsat.noaa.gov, or at www.beaconregistration.noaa.gov.

A registration form (U.S. registration only) is attached to this manual. Please make certain to read the "Important Notice" attached. The form can be mailed or faxed to NOAA. The mailing address and fax number are located in the upper right corner of the registration form.

Make sure that the 15-Hex ID on the front label of the ELT is properly entered on the form. Also, enter all required information. If you register online, a confirmation letter with your completed registration form will be sent immediately via email or fax. If you registered by mail, the confirmation letter should arrive within two weeks. Once you receive your registration confirmation, review it carefully. You should also receive within two weeks a NOAA Proof of Registration Decal by mail. If you do not, please call NOAA toll-free at: 1-888-212-7283. This decal should be affixed to the beacon so that it is visible.

Failure to register or re-register as required every two years, or to notify NOAA of any changes to the status of your 406 MHz beacon could result in penalties and/or fines being issued under federal law.

REGISTERING YOUR ELT (OUTSIDE OF THE USA)

If you intend to use this ELT in another country, then you must register with the responsible national authority in that specific country.

SECTION 3

DESCRIPTION OF ELT TOGGLE SWITCH POSITIONS

ON position:

This position (closest to the antenna connector) activates the ELT. The ELT will begin radiating a distress signal on 121.500 MHz, and within 50 seconds, will radiate an emergency coded signal on 406.028 MHz.

ARM position:

This position (center position) is the normal operating position for the ELT. When properly installed in its mount, the ELT is armed and ready to activate if an accident is sensed. When removed from its mount, the G-switch is disabled, and any mishandling will not result in activation.

TEST-RESET position:

This position (closest to the LED) is used to self-test, and to deactivate the ELT.

To **deactivate** the ELT, momentarily hold the switch in this position (closest to LED), hold for about one second and quickly release. The ELT will perform a self-test, and then deactivate. See **Section 9** for self-test results.

To **self-test** the ELT, momentarily move the handle from the center position to the "**TEST-RESET**" position; hold for about one second and quickly release. The ELT will perform a self-test, and then deactivate. Refer to **Section 9** for self-test results.

DISABLING THE AUTOMATIC ACTIVATION FEATURE

The ELT's G-switch is enabled **ONLY** when the ELT is properly attached to a mating connector that has a jumper from pin 1 to pin 11. Without this jumper, the ELT will not automatically activate in the event of a crash. When removed from its tray, and the mating connector disconnected, the G-switch is disabled to prevent inadvertent activation. Please note that the ELT can still be manually activated via its toggle switch.

It is recommended that the homer signal be monitored on a radio tuned to 121.500 MHz.

SECTION 4

DESCRIPTION OF REMOTE CONTROL MONITOR TOGGLE SWITCH POSITIONS

NOTE: WHEN PERFORMING A SELF-TEST FROM THE REMOTE CONTROL MONITOR, FIRST SET THE TOGGLE SWITCH TO THE “ON” POSITION FOR 1 SECOND, AND THEN MOMENTARILY SET IT TO THE “TEST-RESET” POSITION AND QUICKLY RELEASE.

The Remote Control Monitor is provided for the EBC-406AFH where the ELT is mounted in the aft section of the aircraft, and the ELT controls are not readily accessible from the pilot's position.

ON position:

This position activates the ELT. The ELT will begin radiating a distressed signal on 121.500 MHz, and within 50 seconds, will radiate an emergency coded signal on 406.028 MHz.

ARM position:

This position (center position) is the normal operating position for the ELT. When properly installed in its mount, the ELT is armed and ready to activate if an accident is sensed. When removed from its mount, the G-switch is disabled, and any mishandling will not result in activation.

TEST-RESET position:

This position is used to self-test and deactivate the ELT. There is a slight difference of operation between the ELT toggle switch and the Remote Control Monitor toggle switch, but only when performing a self-test.

To deactivate the ELT, momentarily hold the Remote Control Monitor toggle switch in the “**TEST-RESET**” position, hold for about one second and quickly release. This position is spring loaded, and it will return to the ARM position. The ELT will perform a self-test, and then deactivate. See **Section 9** for self-test results.

To **self-test** the ELT, from the Remote Control Monitor, first move the handle from the center position to the “**ON**” position for about one second and then momentarily move the handle to the “**TEST-RESET**” position; hold for about one second and quickly release. The ELT will indicate a pass or fail by flashing/beeping one or more codes depending on test results. Refer to **Section 9** for self-test results.

DISABLING THE AUTOMATIC ACTIVATION FEATURE

The ELT's G-switch is enabled ONLY when the ELT is properly attached to a mating connector that has a jumper from pin 1 to pin 11. Without this jumper, the ELT will not automatically activate in the event of a crash. When removed from its tray, and the mating connector disconnected, the G-switch is disabled to prevent inadvertent activation. Please note that the ELT can still be manually activated via its toggle switch.

It is recommended that the homer signal be monitored on a radio tuned to 121.500 MHz.

SECTION 5

ELT INSTALLATION

RTCA Document DO-183 paragraph 3.1.8 describes the mounting requirements which must be followed when choosing a location on which to mount an ELT. It reads as follows:

THE ELT SHALL BE MOUNTED TO PRIMARY AIRCRAFT LOAD CARRYING STRUCTURES SUCH AS TRUSSES, BULKHEADS, LONGERONS, SPARS, OR FLOOR BEAMS (NOT AIRCRAFT SKIN). THE MOUNTS SHALL HAVE A MINIMUM STATIC LOCAL DEFLECTION NO GREATER THAN 2.5mm (0.1 INCH) WHEN A FORCE OF 450 NEWTONS (100 lbs) IS APPLIED TO THE MOUNT IN THE MOST FLEXIBLE DIRECTION. DEFLECTION MEASUREMENTS SHALL BE MADE WITH REFERENCE TO ANOTHER PART OF THE AIRFRAME NOT LESS THAN 0.3 METER (1 FOOT) NOR MORE THAN 1.0 METER (3 FEET) FROM THE MOUNTING LOCATION.

Before any work is performed, it is wise to perform a survey of the available space, pathways, and airframe area needed to mount the ELT, Remote Control Monitor, coaxial cable, Remote Control Monitor harness, and antenna. These items can be installed in any order, except that improper installation of any of these components can result in poor performance or non-operation.

The EBC-406AFH ELT system is comprised of a transmitter, mounting tray, coaxial cable, external antenna and a remote control monitor. Take into account the following:

- Mount the ELT and external antenna as close to each other as possible and practical.
- The external antenna, ELT and coaxial cable should be mounted between the same two bulkheads, and should not cross a production break.
- If the antenna is to be mounted on a non-metallic surface, a supplementary ground plane must be installed.
- Mount the ELT in the aft portion of the fuselage (preferably on a horizontal surface) near an inspection access panel. Allow accessibility for maintenance and the possible need for portable operation.
- The location chosen to install the ELT must provide rigidity and must not be subject to vibration that could cause activation.
- Use the mounting tray as a template to mark out the holes needed for installation.
- Attach the mounting tray using accepted procedures. It must be secured to a rigid member of the aircraft so that a force of 100 lbs applied to it will not cause a movement greater than 0.1 inch.
- Install so that all the requirements of FAR 91.52 and FAR 23 or FAR 25 are met.
- Mount the tray using fasteners that comply with FAR 23.561 or FAR 25.561.
- Do not install the mounting tray to thin unsupported skin or fabric.

SECTION 6

EXTERNAL ANTENNA INSTALLATION (ANT-406W)

Install antenna in a manner consistent with acceptable workmanship, engineering practices, and in accordance with the following instructions:

- Mount in the upper portion of the fuselage, aft of the pilot, and a minimum of 2 feet from any VHF communications antennas. It should not foul other antennas in flight. The antenna should be mounted as close as possible to the transmitter.
- A .515-inch diameter hole is required. A doubler plate should be fabricated if needed. Secure the antenna to the aircraft with the washer and nut provided, and torque to 30-inch/pound max.
- If the antenna is being installed on a non-metallic surface, a supplementary ground plane must be installed. Install the antenna using supplied hardware.
- To ensure the system has been properly installed on the aircraft, the installer should make a thorough visual inspection and conduct an overall operational and functional check of the system on the ground prior to flight

WARNING: Do not use the ANT-406T portable antenna in place of the external antenna. Do not connect any length of coaxial cable or connectors between the ELT and the ANT-406T portable antenna. The portable antenna must be attached directly to the ELT. The portable antenna is secured to the ELT with a lanyard. Do not separate the ANT-406T antenna from the lanyard. If the antenna becomes detached from the lanyard, it must be reattached immediately.

**SECTION 7
REMOTE CONTROL MONITOR INSTALLATION**

The Remote Control Monitor allows the pilot to activate, self-test, and reset the ELT from the cockpit. It also functions to alert the pilot or copilot of self-test results, and/or ELT activation. It should be installed where the pilot can easily reach it. A panel cutout of **1.85"** by **1.15"**, and a behind the panel depth of at least **4.2"** is required for proper installation. See Figure 1 below.

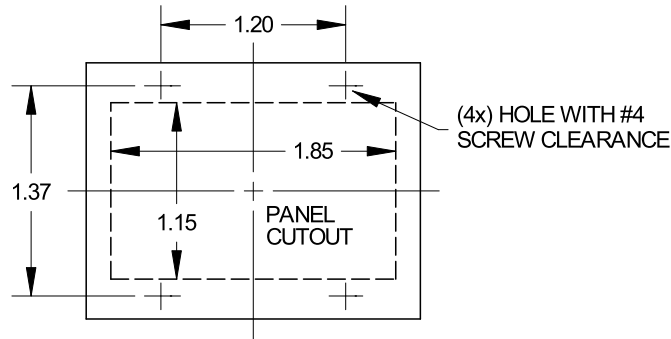

FIGURE 1: REMOTE CONTROL MONITOR PANEL Fabricate harness of sufficient length using supplied connectors. Use four #22 or #20 AWG wires. Use shielded cable where electrical interference is high, and connect the shield to pin 4 of the 15 pin D-Sub connector. Verify that all toggle switches are set to the "ARM" position (center position).

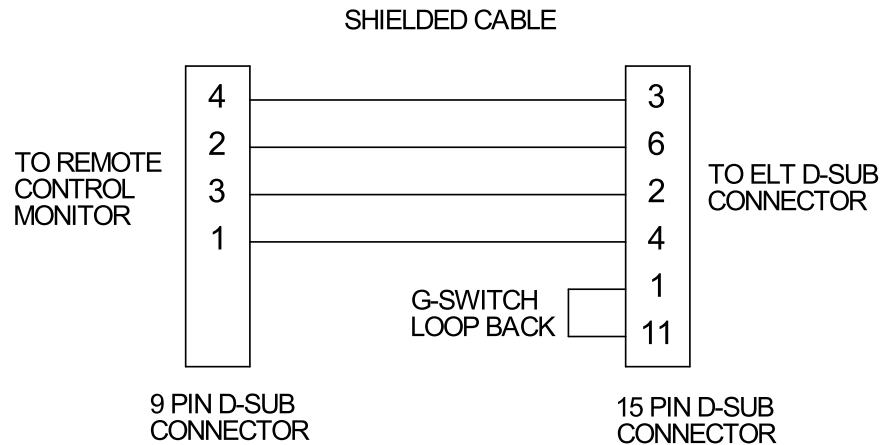

FIGURE 2: EBC-406AFH HARNESS WIRING DIAGRAM

SECTION 8 FINAL INSTALLATION AND TEST

BEFORE PERFORMING THESE TESTS, DISCONNECT THE EXTERNAL ANTENNA COAXIAL CABLE FROM THE ELT!

Before installing the ELT in its tray, verify that the G-switch is operational; it will be necessary to fabricate a jumper:

Method 1 - Obtain a D-sub 15 pin male mating connector, and solder a wire between pin 1 and pin 11 of this mating connector. Install mating connector to ELT connector.

Method 2 - Remove ELT from mount and place a #24 AWG jumper between pins 1 and 4 of the ELT D-sub connector.

Test the G-switches by performing two (2) tests. Hold the ELT vertical with your arm fully extended horizontally. Swing the ELT around your body (like a forehand tennis swing) in the horizontal plane as fast as possible, keeping the ELT pointed up. This may take some practice since it takes a great deal of force to simulate a crash. Verify that the ELT has been activated by the use of a VHF COM receiver tuned to 121.500 MHz. Reset the ELT. Next, hold the ELT in a horizontal position with the antenna side away from you, and swing in the same manner as before. Listen for proper activation. Reset the ELT. Please note that these are not measured checks, and thus only indicate that the G-switch is working, and that the ELT homer is radiating sufficient power to aid search and rescue. Remove the jumper, and reset the ELT.

IMMEDIATELY RESET THE ELT, AS A LIVE 406 SIGNAL WILL BE TRANSMITTED!

Removing the antenna coaxial cable during the G-switch test assures that no signal will be transmitted to the satellites. This is vital in order that no false alarms be transmitted. Once activated, the signal can be monitored on the aircraft's COM radio; at close distances (a few feet) a strong 121.5 MHz homer signal can be detected by a COM even though an antenna is not attached to the ELT.

Install the ELT into the mounting tray front side down, until the ELT is fully seated in the tray. Verify the proper direction for crash activation, and secure in place by closing latch. Install antenna BNC cable, and install remote control harness connector, and tighten thumbscrews. Perform a self-test. It is recommended that these tests receive prior approval of the nearest control tower. FAA and FCC regulations require that a transmitter test be performed only during the first 5 minutes of each hour and last no longer than 3 audio sweeps.

After the EBC-406APH is installed into its mounting tray, perform a self-test to verify ELT operation. It is recommended that such tests receive prior approval of the nearest control tower. FAA and FCC regulations require that transmitter tests be performed only during the first 5 minutes of each hour and last no longer than 3 audio sweeps.

SECTION 9 DESCRIPTION OF SELF-TEST MODE AND ERROR CODES

Note: Self-tests can be actuated from the ELT's toggle switch, or from the Remote Control Monitor's toggle switch.

Set the Remote Control Monitor's toggle switch to the "ON" position for about 1 second, and then momentarily place the toggle switch in the spring-loaded "TEST-RESET" position for about 1 second, and quickly release. The self-test event occurs in the following manner:

The ELT energizes its LED/buzzer for about 1 second

The ELT transmits three locator beacon audio sweeps on 121.500 MHz.

The ELT transmits one 406.028 MHz self-test burst.

During these transmissions, the ELT will perform a number of internal tests on its data and electronics.

If the ELT has passed all tests, the LED/buzzer will flash/beep for one second, and then de-energize.

If the ELT has not passed any or all of its tests, the LED/buzzer will flash/beep for one second, and de-energize for ½ second. Following this, the failure(s) are indicated by one or more error indications of the LED/buzzer.

The cadence of these on-off intervals will cause the LED/buzzer to flash/beep for ¼ of a second interval followed by ¼ second de-energized interval.

In the event that the ELT needs to signal multiple self-test failures, several LED/buzzer on-off sequences will follow, one after the other, and each sequence separated by a LED/buzzer de-energized interval of one second.

A SELF-TEST PASS IS INDICATED BY 1 FLASH/BEEP.

Self-test failure error codes are as follows:

Missing G-Switch Loop Back	2 flashes/beeps.
Bad 121.500 MHz RF Output Power	3 flashes/beeps.
Bad 406 MHz RF VSWR	4 flashes/beeps.
Low 406 RF Power Output	5 flashes/beeps.
Bad EEPROM Data	6 flashes/beeps.
Bad RAM	7 flashes/beeps.

MEANING OF ERROR CODES

Missing G-switch loop back; can indicate that the ELT is not fully seated in its mount, or the mating connector is not properly attached. It can also indicate a missing jumper from pin 2 to pin 9. This condition renders the G-switch inoperative.

Bad 121.500 MHz Output Power; can indicate that the homer signal on 121.500 MHz is not operating.

Bad 406 MHz VSWR; can indicate a faulty antenna, cable, or connection between the ELT and the external antenna

Low 406 RF Power Output; can indicate a low voltage battery, or defective 406 power amplifier.

Bad EEPROM Data; can indicate a hardware or software fault. ELT will only transmit on 121.500 MHz.

Bad RAM; can indicate a hardware or software fault. ELT will only transmit on 121.500 MHz.

NOTE: ALL ERROR CODES REQUIRE IMMEDIATE ATTENTION!

DO NOT ACTIVATE THE TRANSMITTER UNTIL YOU THOROUGHLY UNDERSTAND HOW TO DEACTIVATE IT!

**SECTION 10
OPERATING INSTRUCTIONS**

The EBC-406AFH is for aviation emergency use only. In an accident with sufficient G-forces, the ELT is automatically activated. The ELT can be manually activated by setting the ELTs toggle switch to the "ON" position, or by setting the Remote Control Monitor toggle switch on the instrument panel to the "ON" position. If possible after an accident, inspect the antenna for damage.

When the ELT is automatically or manually activated, there is a 1 second delay before the 121.500 MHz homer transmitter is activated. This is followed approximately 50 seconds later by the 406 burst.

REMOVING THE EBC-406AFH FROM ITS TRAY

Remove the BNC connector on the ELT by pushing it in and turning counterclockwise, then pulling it out.

Remove the Remote Control Monitor mating connector by turning the two thumbscrews counterclockwise.

Release the latch on the strap by simultaneously pushing on the secondary catch with thumb while pulling on the primary latch with forefinger. Lift the ELT off the tray.

Attach the portable antenna.

Place the ELT on high ground with the antenna in a vertical position. If using at temperatures below -20° C, for the longest operating life, keep the transmitter inside a jacket with the antenna outside.

SELF-TEST SCHEDULE

Self-Test the ELT from the remote control monitor, a minimum of once every three months.

Once a year perform the periodic maintenance test in Section 11.

SECTION 11 PERIODIC MAINTENANCE

THIS INSPECTION PROCEDURE IS BASED ON FAA AC 43.13-1B CHG 1, DATED SEP. 27, 2001..

NOTE: The FCC has mandated that the transmitter test be performed only during the first 5 minutes of each hour and last no longer than 3 audio sweeps of the ELT signal. The test must be performed a minimum of once a year.

1. Remove all interconnections between the ELT unit, the antenna, and the Remote Control Monitor. Visually inspect and confirm proper seating of all connector pins. Special attention should be given to coaxial center conductor pins, which are prone to retracting into the conductor housing.
2. Remove the ELT from the mount and inspect the mount hardware. All required mounting hardware should be reinstalled and secured.
3. Inspect the battery pack. No corrosion should be detectable. Verify that the ELT battery is an approved pack, GS-46, manufactured by Emergency Beacon Corporation. Check the battery pack's expiration date.
4. To test the G-switch, disconnect the external antenna coaxial cable, and remove ELT from its mount. It is necessary to place a jumper between pin 1 and pin 11 of the ELTs connector. This is accomplished by using a mating 15-pin D-Sub male connector with a jumper between pin 1 and pin 11. Without this jumper, the ELTs auto activation feature is disabled.
5. To test the G-switch circuitry, it will be necessary to perform two (2) tests. Hold the ELT vertical with your arm fully extended horizontally. Swing the ELT around your body (like a forehand tennis swing) in the horizontal plane as fast as possible, keeping the ELT pointed up. This may take some practice since it takes a great deal of force to simulate a crash (see note 1 below). Proper activation is indicated when the PEOW-PEOW signal is heard through the radio (see note 2). Reset the ELT. Next, hold the ELT in a horizontal position with the antenna side away from you, and swing in the same manner as before. Listen for proper activation. Reset the ELT. (See note 1).
Reset the ELT. Next, hold the ELT in a horizontal position with the antenna pointed away from you, and swing in the same manner as before. Listen for proper activation. Reset the ELT. (See note 1).
6. Immediately reset the ELT, as a real 406 distress signal will be radiated within 50 seconds.
7. Remove the jumper and reinstall the ELT into its mounting tray and verify the proper direction for crash activation. Reconnect all cables. They should have some slack at each end and be properly secured to the airplane's structure for support and protection.
8. Perform a self-test, and verify pass-fail error codes as described in Section 9.
9. Verify that all switches are properly labeled and positioned.

Notes:

1. This is not a precise check; thus, it only indicates that the G-switches are working.
2. This is not a measured check. It is an indication that the ELT is radiating a sufficient signal to aid search and rescue.

SECTION 12 EQUIPMENT LIMITATIONS

The conditions and tests required for TSO approval of this article are minimum performance standards. It is the responsibility of those desiring to install this article on a specific type or class of aircraft to determine that the aircraft installation conditions are within the TSO standards. The article may be installed only if further evaluation by the applicant documents an acceptable installation and it is approved by the Administrator.

This equipment must be installed according to the recommendations outlined in this manual. Only Emergency Beacon Corporation TSO approved parts are to be used. Substitution of other components will void the warranty. Any deviation may result in failure of the equipment to operate properly.

SECTION 13 BATTERY REPLACEMENT

FAR 91.207(c) requires that the battery in the ELT be replaced in accordance with the replacement date marked on the ELT or when the transmitter has been in use for more than one cumulative hour. The battery replace label with the replacement date is found on the exterior of the ELT and on the replacement battery. This battery pack must be replaced every 5 years or after one hour of cumulative use. The battery should not be stored in a location where the ambient temperature is above 80°C, or below -40°C.

WARNING: The EBC-406AFH must be used only with battery pack, P/N GS-46. The ELT will not meet the requirements of TSO-C126 if used with another type of battery. GS-46 battery packs are available from Emergency Beacon Corporation and its dealers.

BATTERY INSTALLATION PROCEDURE:

1. Verify that the ELT is off, and remove from its mount.
2. Unscrew the 4 back cover screws and remove cover.
3. Observe the manner in which the battery is situated within the ELT. The new battery must be installed in the same physical orientation as the current battery.
4. Remove the plastic U strip spacer.
5. Grasp black connectors, and pull apart. Do not pull on wires or they may be damaged.
6. Verify that the contacts on the battery connector, BNC connector, and d-sub connector are free of corrosion. Clean as required.
7. Install new battery with label facing up. Tightly mate battery connectors. This is very important to protect the contacts from corrosion.
8. Install plastic U strip spacer.
9. Remove the "replace by" label, and place on the side of the ELT.
10. Reinstall cover, install into mounting tray, and reconnect coax cable.
11. Perform self-test as per Section 9.

The Part Number for a replacement battery pack is GS-46.

CAUTIONS:

This battery pack is comprised of lithium manganese dioxide cells. Do not disassemble the battery pack. Do not short circuit. Lithium is flammable. Do not dispose of the battery pack in or near fire or flame.

The conditions and tests required for this TSO approval of this battery are minimum performance standards. It is the responsibility of those desiring to install this battery in a specific class of aircraft to determine that the aircraft installation conditions are within the TSO standards. The battery may be installed only if further evaluation by the applicant documents an acceptable installation and is approved by the administrator. Lithium battery safety concerns include the possibility of fire, venting violently, and venting toxic gasses.

Battery Specifications:

System: Non-rechargeable Lithium Manganese Dioxide
Nominal Open Circuit Voltage ... 9.8 VDC, Red lead positive
Total Lithium Content..... 10.2 grams
Nominal Size..... Height = 2.53" Width = 1.42" Length = 4.14"
Nominal Weight Approximately 1.2lbs.
Certification..... TSO-C142

GS-46 ENVIRONMENTAL QUALIFICATION FORM

APPLICABLE SPECIFICATIONS: RTCA DO-227, RTCA DO-204, RTCA DO-160C
 ENVIROMENTAL CATEGORY: 227/227/227/227/204/204/XXXXXXXXXXXXXXXXXX

TEST CONDITIONS	Section DO-160C	Paragraph	Category
Survival Low / High Temperature Cycle	-	2.3.3	Per DO-227
Altitude	-	2.3.4	Per DO-227
Decompression	-	2.3.5	Per DO-227
Humidity	-	2.3.6	Per DO-227
Shock	-	2.3.4.1	Per DO-204
Vibration	8.0	2.3.5	Per DO-160C/204
Explosion Proofness	9.0	-	X
Waterproofness	10.0	-	X
Fluids Susceptibility	11.0	-	X
Sand and Dust	12.0	-	X
Fungus Resistance	13.0	-	X
Salt Spray	14.2	-	X
Magnetic Effect	15.0	-	X
Power Input	16.0	-	X
Voltage Spike	17.0	-	X
Audio Freq. Conducted Susceptibility	18.0	-	X
Induced Signal Susceptibility	19.0	-	X
R.F. Susceptibility	20.0	-	X
Emission of R.F. Energy	21.0	-	X
Lightning Induced Transient Susceptibility.	22.0	-	X
Lightning Direct Effects	23.0	-	X
Icing	24.0	-	X

EBC-406AFH ENVIRONMENTAL QUALIFICATION FORM

Nomenclature: 406 / 121.5 MHz Emergency Locator Transmitter.

Part Numbers: EBC-406AFH, BB-14, RCM-1, AC-406, GS-46 **TSO Number:** C126

Other Applicable Specifications: RTCA DO-204

Manufacturer: Emergency Beacon Corporation **Address:** 15 River Street, New Rochelle, New York

Revision of DO-160: C and D **Tests started:** 5/20/06. **Tests completed:** 2/25/07.

ENVIRONMENTAL CATEGORIES: D1XBC(204)(204)XRFXXSXXXXXZ(204)X(A1C1)XXA

CONDITIONS	SECTION	DESCRIPTION OF TESTS CONDUCTED
TEMPERATURE AND ALTITUDE	4.0	EQUIPMENT TESTED TO CATEGORY D1
OPERATING LOW TEMPERATURE	4.5.1	EQUIPMENT TESTED TO CATEGORY D1
OPERATING HIGH TEMPERATURE	4.5.2 & 4.5.3	EQUIPMENT TESTED TO CATEGORY D1
IN-FLIGHT LOSS OF COOLING	4.5.4	NOT APPLICABLE
ALTITUDE	4.6.1	EQUIPMENT TESTED TO CATEGORY D1
DECOMPRESSION	4.6.2	EQUIPMENT TESTED TO CATEGORY D1
OVERPRESSURE	4.6.3	EQUIPMENT TESTED TO 170 kPa abs.
TEMPERATURE VARIATION	5.0	EQUIPMENT TESTED TO CATEGORY B
HUMIDITY	6.0	EQUIPMENT TESTED TO CATEGORY C
OPERATIONAL SHOCK	7.0	EQUIPMENT TESTED TO CATEGORY (204)
OPERATIONAL CRASH SAFETY	7.0	EQUIPMENT TESTED TO CATEGORY (204)
VIBRATION	8.0	EQUIPMENT TESTED TO CATEGORY (204)
EXPLOSION	9.0	NOT APPLICABLE
WATERPROOFNESS	10.0	EQUIPMENT TESTED TO CATEGORY R
FLUIDS SUSCEPTIBILITY (salt water)	11.0	EQUIPMENT TESTED TO CATEGORY F
SAND AND DUST	12.0	NOT APPLICABLE
FUNGUS	13.0	NOT APPLICABLE
SALT SPRAY	14.0	EQUIPMENT TESTED TO CATEGORY S
MAGNETIC EFFECT	15.0	NOT APPLICABLE
POWER INPUT	16.0	NOT APPLICABLE
VOLTAGE SPIKE	17.0	NOT APPLICABLE
AUDIO FREQUENCY SUSCEPTIBILITY	18.0	NOT APPLICABLE
INDUCED SIGNAL SUSCEPTIBILITY	19.0	EQUIPMENT TESTED TO CATEGORY Z
RADIO FREQUENCY SUSCEPTIBILITY	20.0	EQUIPMENT TESTED TO CATEGORY (204)
RADIO FREQUENCY EMISSION	21.0	NOT APPLICABLE
LIGHTNING INDUCED TRANSIENT SUSCEPTIBILITY	22.0	EQUIPMENT TESTED TO CATEGORY A1C1
LIGHTNING DIRECT EFFECTS	23.0	NOT APPLICABLE
ICING	24.0	NOT APPLICABLE
ELECTROSTATIC DISCHARGE	25.0 (DO-160D)	EQUIPMENT TESTED TO CATEGORY A

OTHER DO-204 ENVIRONMENTAL TESTS PASSED

CONDITIONS	SECTION	DESCRIPTION OF TESTS CONDUCTED
IMPACT PENETRATION	2.3.4.2	55 LBS IMPACT FROM 6 INCHES TEST
CRUSH	2.3.4.3	1000 LBS APPLIED FORCE CRUSH TEST
FLAME	2.3.7.1	15 SECOND FLAME EXPOSURE TEST
POST CRASH IMMERSION	2.3.9.4	1 METER SALT WATER IMMERSION TEST
OTHER ELECTRONIC TESTS	2.3.2 THRU 2.3.2.6	LOW-TEMP. LIFE, HIGH TEMP., TEMP. GRADIENT/ FREQ. STABILITY, VSWR THERMAL SHOCK, SELF TEST
LONG TERM FREQUENCY DRIFT	2.4.2.1.4	IDENTIFIED AS PER RF OSC. MFG. DATA*

* Not tested but identified as meeting requirement from manufacturer's specifications.

SECTION 14 REPAIRS

Should you experience any problems with your ELT, contact the factory for advice. Should repairs become necessary, disconnect the battery and send the ELT to the factory. Emergency Beacon Corporation is the only authorized repair facility. Please include a note describing the problem. Emergency Beacon Corporation will evaluate the unit and contact you with a repair estimate. There is a nominal fee for this inspection.

SHIPPING INSTRUCTIONS:

- 1 – Verify that the ELT is not transmitting, and that the toggle switch is set to the center position.
- 2 – Enclose a note describing the problem. Include your name, address and telephone number.
- 3 – Pack well and insure.

The customer pays shipping costs to and from the factory.

Send the ELT to:

Emergency Beacon Corporation, 15 River Street, New Rochelle, New York, 10801, USA

SECTION 15 SPECIFICATIONS

Operating Frequencies: 406.028 MHz and 121.500 MHz
Modulation 406 MHz: Biphase L (16KOG1D)
Modulation 121.500 MHz: Swept tone 1600 Hz to 300 Hz, 2-4 times/second
Output Power on 406 MHz: 5W for 24 hours at –20 °C
Output Power on 121.500 MHz: 50 mW min for 50 hours at –20 °C
Operating Temperature: -20 °C to +55 °C
Battery Type: Lithium Manganese Dioxide (GS-46 Battery Pack)
Useful Battery Life: 5 years or 1 hour of cumulative use
Automatic Activation: True 360° spherical 6 axis G-switch system
5-7 G's
Altitude: 50,000 ft
Decompression: 8,000 ft to 50,000 ft
Over Pressure: -15,000 ft
Humidity: 95% for 144 hours
Shock Performance: 500 Gs On 6 Axis for 4ms
100 Gs On 6 Axis for 100ms
Vibration: Withstands 10 Gs
Immersion: Withstands 24 hours in salt water
Message Protocols: Aviation User Protocol, Serialized Aviation User Protocol
Activation Alerts LED and buzzer
Input Power No Aircraft Power Required

PHYSICAL FEATURES:

Size (ELT): Height = 6.7" Width = 2.9" Depth = 2.5"
Total Weight: 2.5 lbs. (including battery, but not antennas)
Case Material: Aluminum
Finish: Yellow Baked Enamel

PLEASE NOTE: ALL WARRANTIES ARE NULL AND VOID IF NON-FACTORY APPROVED BATTERIES ARE EVER USED IN YOUR ELT.

**SECTION 16
EBC-406 TWO YEAR WARRANTY**

FOR YOUR RECORDS:

Type of Equipment: _____

Model No. _____ Serial No. _____

Date Purchased: _____ Dealer: _____

PLEASE NOTE: ALL WARRANTIES ARE NULL AND VOID IF NON-FACTORY APPROVED BATTERIES ARE EVER USED IN YOUR ELT.

The EMERGENCY BEACON CORPORATION instrument you purchased is conservatively designed and was carefully inspected before shipment. Properly operated in accordance with the instructions furnished, it will provide you with trouble-free service. Should repairs become necessary, write or call EMERGENCY BEACON CORPORATION describing symptoms of faulty operation. Instructions will be sent to you for obtaining service, if factory judges necessary, authorization for shipment will be given to you. Do not ship without first obtaining this authorization. Pack well and insure when shipping. Repairs will be made without charge for materials and labor within two years from date of warranty registration. Transportation charges both ways are to be borne by the customer. Beyond this warranty period fair charges will be made for service by skilled personnel using factory approved/new parts. This warranty is void if:

- 1- ELT is damaged in transit.
- 2- ELT is abused in any way.
- 3- Repair is attempted by persons not authorized by EBC.
- 4- Unapproved battery is installed.

EMERGENCY BEACON CORPORATION, 15 River Street, New Rochelle, New York USA 10801
Phone: (914)235-9400 Fax (914)576-7075

(CUT HERE AND RETURN TO FACTORY)

TWO YEAR WARRANTY REGISTRATION

Model No: _____ Serial No: _____

Date Purchased: _____

How did you hear of this product? _____

What persuaded you to purchase it? _____

Dealer: _____ City: _____

My name: _____

Address: _____

City: _____ State: _____ Zip: _____

Return this portion to: EMERGENCY BEACON CORPORATION
15 RIVER ST.
NEW ROCHELLE, NY 10801 USA

PLEASE NOTE: ALL WARRANTIES ARE NULL AND VOID IF NON-FACTORY APPROVED BATTERIES ARE EVER USED IN THE ELT.